



INSTALLATION INSTRUCTIONS

Accessory

CARGO HOOK
P/N 08L96-TA0-101A

Application

2014 ILX

Publications No.

BII 48793

Issue Date

APRIL 2013

PARTS LIST

Cargo hook



Bolt



Small washer



Spring washer



Rivet nut



User's Information Manual

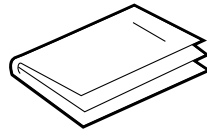

Flange nut
(Not used)



Large washer
(Not used)



TOOLS AND SUPPLIES REQUIRED

Hex wrench

19 mm Open end wrench

10 mm Socket

Ratchet

Extension

Torque wrench

The following tool is available through the Honda Tool and Equipment Program. On the iN, click on: Service > Service Bay > Tool and Equipment Program, then enter the number under "Search". Or, call 888-424-6857.

Rivet Nut Tool, 6 mm (T/N 07AAE-000A100)

INSTALLATION

Client Information: The information in this installation instruction is intended for use only by skilled technicians who have the proper tools, equipment, and training to correctly and safely add equipment to your vehicle. These procedures should not be attempted by "do-it-yourselfers."

NOTE:

- Be careful not to damage the body.
- This instruction shows a cargo hook being installed on the left side of the vehicle. An additional cargo hook (sold separately) can be installed on the right side of the vehicle.

1. Thread the rivet nut onto the mandrel of the rivet nut tool as shown.

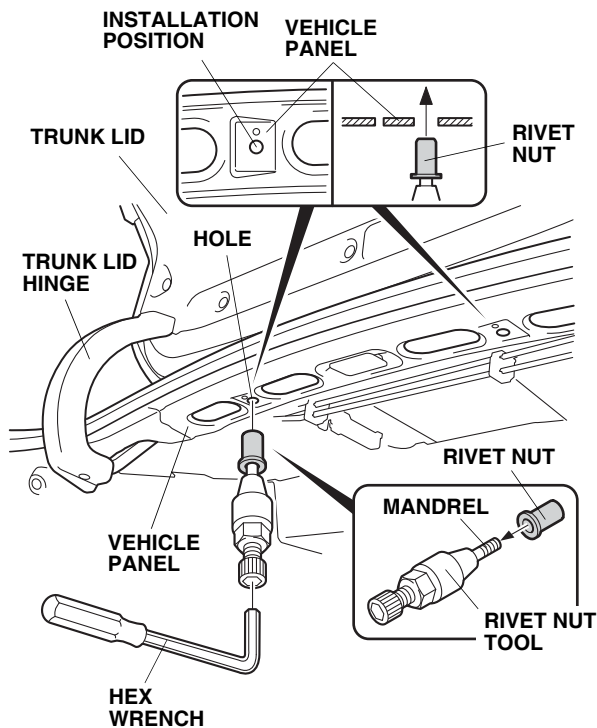

2. Open the trunk. Insert the rivet nut into the hole in the vehicle panel, and install the hex wrench on the rivet nut tool.

3. While holding the rivet nut tool with the hex wrench, turn the 19 mm open end wrench clockwise to install the rivet nut to the vehicle panel.

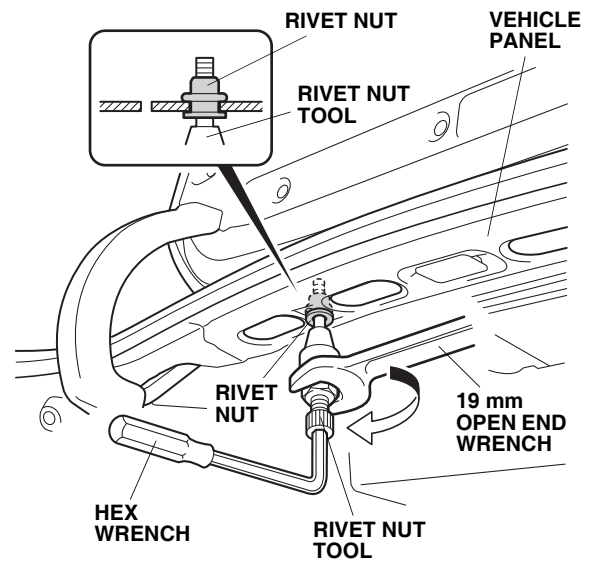

4. Remove the rivet nut tool from the rivet nut by turning the hex wrench counterclockwise.
5. Align the cargo hook pin with the hole in the vehicle panel, and secure the cargo hook to the vehicle panel using the bolt, small washer, and spring washer. Torque the bolt to 4.0 N·m (3.0 lbf·ft).

